



Bushings

Featuring: Center-Bonded Bushings
Square-Bonded Bushings

LORD Center-Bonded Bushings and Square-Bonded Bushings are used in applications where the absorption shock, attenuation of noise, reduction of wear and elimination of lubrication is required.

Center-Bonded Bushings are designed to be loaded radially and utilize a soft torsional spring rate to provide freedom in rotation. High radial restraint maintains the alignment between joined parts. They are not intended for use where extreme rotational motion will occur. Typical applications include heavy duty highway equipment, drilling equipment, harvesters, combines and industrial machinery.

Square-Bonded Bushings accommodate angular movement and isolate vibratory disturbances in heavy equipment. These bushings combine a torsional spring with an elastomeric pivot and isolator. They provide positive torsional positioning and pivot action under the most demanding operating conditions. Typical applications include wheel suspensions, vibratory feeders, mobile power equipment and vibratory cable layers.

Easy to install, the uncomplicated designs of the Center-Bonded and Square-Bonded Bushings provide initial economy, while the rugged elastomers and high strength bonding assure extended service life.

Features and Benefits

- Easy to install
- Uncomplicated design provides initial economy
- High-strength bonding assures extended service life
- Minimal maintenance due to specially compounded elastomer

Center-Bonded Bushings With Outer Member

Table 1 – Specifications and Dimensions

Part Number	Maximum Radial Static Load Rating		Spring Rate Radial (K rad)		Torsional		Recommended Socket Dimensions			
	lb	N	lb/in	N/mm	lb-in/deg	N-mm/deg	Diameter		Length	
							in ±0.001	mm	in	mm
J-3830-13	300	1334	14,000	2451	3.6	410	1.245	31.6	0.88	22.35
J-5385-31	1000	4448	36,600	6408	18.7	2128	1.743	44.3	2.00	50.80
J-6729-2	6000	26,689	150,000	26,265	119	13542	1.996	50.7	4.00	101.60
J-6740-3	9300	41,368	256,000	44,825	475	54055	3.231	82.1	4.00	101.60

Table 2 – Specifications and Dimensions

Part Number	Part Dimensions							
	A		B		C		D	
	in	mm	in	mm	in	mm	in	mm
J-3830-13	0.516	13.1	1.253	31.8	1.00	25.4	0.75	19.1
J-5385-31	0.504	12.8	1.750	44.5	2.62	66.5	1.00	25.4
J-6729-2	1.129	28.7	2.000	50.8	4.25	108.0	1.31	33.3
J-6740-3	1.500	38.1	3.234	82.1	7.50	190.5	2.12	53.8

Figure 1 – Part Dimensions (With Outer member)

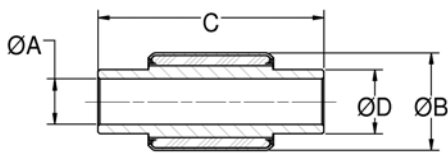

Figure 2 – Part Dimensions (Without Outer Member)

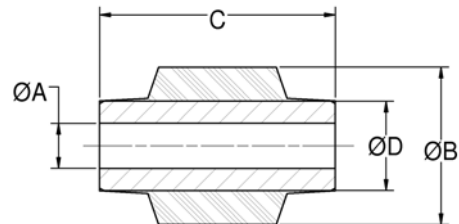
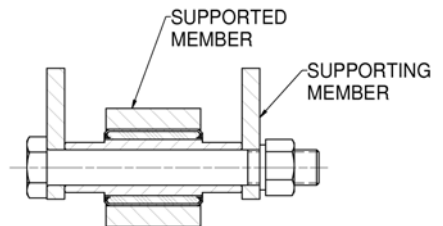

Figure 3 – Installation View



First determine the amount of static loading at the installation point. Then determine the conditions under which the joint will operate. The following should be used as a guide to part selection for Type “A” and Type “B” service.

TYPE A: Extreme conditions (reversing dynamic load or distortion at high frequency – over 600 cpm), use 1/3 the Radial Static Load Rating.

TYPE B: Average conditions (constant radial load, intermittent shock), use the Radial Static Load Rating.

Center-Bonded Bushings Without Outer Member

Table 3 – Specifications and Dimensions

Part Number	Maximum Radial Static Load Rating		Spring Rate Radial (K rad)		Torsional		Recommended Socket Dimensions			
	lb	N	lb/in	N/mm	lb-in/deg	N-mm/deg	Diameter ①		Length	
							in ±0.001	mm	in	mm
J-3830-6	200	890	13,700	2398	4.8	546	1.06	27.05	0.88	22.35
J-2005-2	250	1112	14,800	2591	3.0	339	0.70	17.78	1.00	25.40
J-4705-2	625	2780	25,200	4412	16	1906	1.28	32.63	1.44	36.58
J-6424-1	780	3470	39,200	6863	23	2597	1.37	34.92	1.47	37.34
J-6310-1	925	4115	27,500	4815	25	2823	1.72	44.68	1.56	39.62
J-5385-32	1000	4448	26,200	4587	24	2710	1.58	40.25	2.12	53.85
J-5950	1125	5004	40,000	7004	94	10613	2.22	56.38	1.88	47.75
J-5506	1800	8007	24,600	4307	58	6548	2.75	69.85	2.25	57.15
J-7121-2	1950	8674	105,000	18,385	100	11290	1.75	44.45	2.75	69.85
J-7231-1	2075	9230	168,000	29,416	81	9145	2.44	61.97	1.81	45.97
J-5807-1	2700	12,010	96,000	16,809	105	11055	2.31	58.67	3.00	76.20
J-5971	3200	14,234	102,000	17,860	260	29356	3.70	93.98	2.25	57.15
J-6729	5250	23,353	164,000	28,716	123	13887	1.75	44.45	4.00	101.60
J-6145	8200	36,475	312,000	54,631	796	89868	4.00	101.60	4.00	101.60

For installation instructions, refer to Bushings, Installation Guide section.

① Tolerance is ± 0.015 in (± 0.381 mm) for joints without outer member.

Table 4 – Specifications and Dimensions

Part Number	Part Dimensions							
	A		B		C		D	
	in	mm	in	mm	in	mm	in	mm
J-3830-6	0.517	13.1	1.12	28.4	1.00	25.4	0.75	19.1
J-2005-2	0.315	8.0	0.75	19.1	1.06	26.9	0.44	11.2
J-4705-2	0.641	16.3	1.37	34.8	1.63	41.4	0.88	22.4
J-6424-1	0.627	15.9	1.45	36.8	1.53	38.9	1.00	25.4
J-6310-1	1.004	25.5	1.84	46.7	1.69	42.9	1.25	31.8
J-5385-32	0.504	12.8	1.75	44.5	2.62	66.5	1.00	25.4
J-5950	1.316	33.4	2.39	60.7	2.24	56.9	1.50	38.1
J-5506	1.360	34.5	2.97	75.4	2.75	69.9	2.00	50.8
J-7121-2	1.003	25.5	1.94	49.3	2.99	75.9	1.19	30.2
J-7231-1	1.457	36.9	2.63	66.8	1.94	49.3	2.00	50.8
J-5807-1	1.251	31.8	2.47	62.7	3.37	85.6	1.62	41.1
J-5971	1.503	38.2	3.93	99.8	2.50	63.5	3.00	76.2
J-6729	1.129	28.7	1.86	47.2	4.25	108.0	1.31	33.3
J-6145	2.008	51.0	4.19	106.4	6.00	152.4	3.25	82.6

Square-Bonded Bushings

Table 1 – Specifications and Dimensions

Part Number	Maximum Radial Static Load Rating		Radial Spring Rate (K rad)		Static Torque @ 15 degrees ①		Key Location	Part Dimensions					
	lb	N	lb/in	N/mm	lb-in	N-mm		A		B		C	
								in	mm	in	mm	in	mm
J-6450-19	700	3114	25,000	4378	400	45,212	Y	1.75	44.5	2.62	66.5	0.626	15.9
J-8203-19	1700	7562	60,000	10,506	1500	169,545	Y	2.38	60.5	3.25	82.6	1.379	35.0
J-8203-35	1700	7562	100,000	17,510	2400	271,272	Y	2.40	61.0	3.25	82.6	1.379	35.0
J-9832-11	5000	22,241	160,000	28,016	5200	587,756	X	3.42	86.9	4.00	101.6	2.009	51.0

For installation instructions, refer to Bushings, Installation Guide section.

① Rated static angular deflection is 15° for all parts. Maximum recommended deflection, static plus dynamic is 45° for all parts. Heavy wall tubing is recommended for proper operation.

Table 2 – Specifications and Dimensions

Part Number	Part Dimensions													
	D		E		F		G		H		I		J	
	in	mm	in	mm	in	mm	in	mm	in	mm	in	mm	in	mm
J-6450-19	1.00	25.4	1.17	29.7	1.62	41.1	1.75	44.5	0.191	4.9	0.719	18.3	0.09	2.3
J-8203-19	1.62	41.1	2.15	54.6	2.25	57.2	3.00	76.2	0.191	4.9	1.444	36.7	0.09	2.3
J-8203-35	1.62	41.1	2.15	54.6	2.25	57.2	3.00	76.2	0.191	4.9	1.442	36.7	0.09	2.3
J-9832-11	2.53	64.3	2.50	63.5	3.25	82.6	3.75	95.3	0.253	6.4	2.128	54.1	0.09	2.3

To select a Square-Bonded Bushing for your requirements, compute the static torsional load it must support. Select from Tables 1-2, a bushing with static torque at 15° which is equal to or greater than the computed load.

Compute the static plus the dynamic torsional load. If this total load exceeds three times the static torque at 15°, select a larger size static torque rating part. Static radial load should also be computed and compared to the maximum static radial load listed above. Dynamic plus static radial load can also be three times loads listed above.

Figure 1 – Part Dimensions

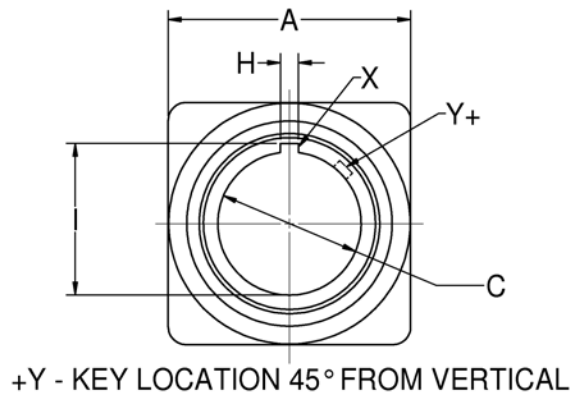
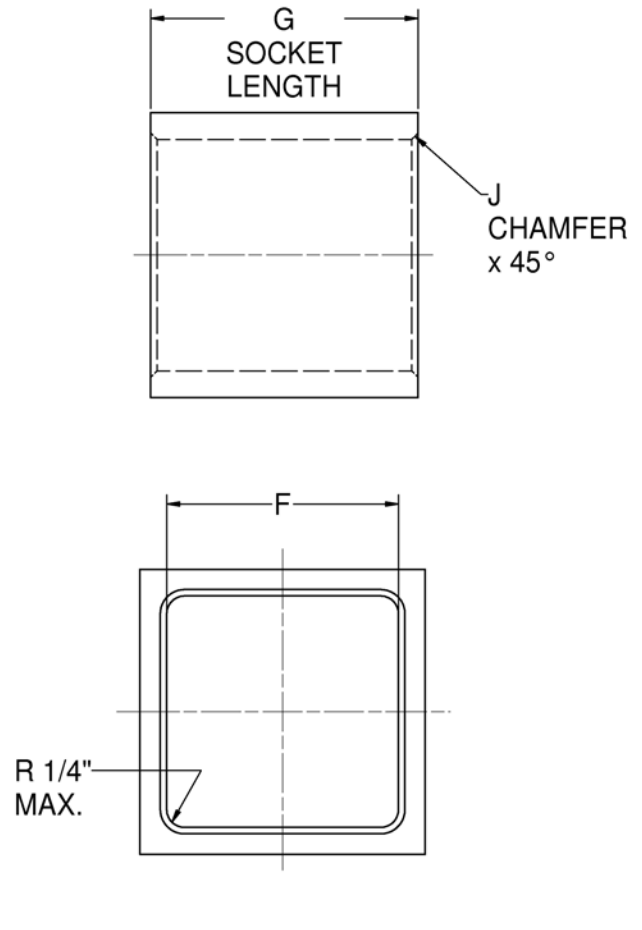

Figure 2 – Installation View



Installation Guide

Center-Bonded Bushing With Outer Member

Clamp or press-fit the outer member into a socket which has been machined to the dimensions shown on Center-Bonded Bushings with Outer Member – Table 1. The force required to install the joint in the socket with a press-fit can be approximated from the formula:

$$\text{Force (lb)} = 2500 \times \text{diameter} \times \text{length}$$

The inner member is normally attached by clamping or bolting its extended ends to a mounting bracket. An alternate method would be to press-fit a shaft through the inner tube.

Center-Bonded Bushing Without Outer Member

Since the outer part of this type joint is the flexing element, it must be compressed and inserted directly into a socket which has been machined to the dimensions shown on Center-Bonded Bushings without Outer Member – Table 3. This is done with the aid of a funnel-shaped fixture and a suitable lubricant: P-80 Rubber Emulsion Lubricant made by International Products Corporation; P. O. Box 70; Burlington, NJ 08016-0070; Phone: (609) 386-8770; Fax: (609) 386-8438.

The inner member attachment is accomplished in the same manner as described above for the joint with outer member.

Square-Bonded Bushings

Joints may be installed in preformed sockets machined, cast or fabricated to dimensions as shown in Square-Bonded Bushings – Table 1.

Installation is a simple, four-step procedure:

1. Lubricate the mount and socket lightly with P-80 Rubber Emulsion Lubricant or water. Lubricant available from International Products Corporation; P. O. Box 70; Burlington, NJ 08016-0070; Phone: (609) 386-8770; Fax: (609) 386-8438.
2. Insert assembly fixture or driving bolt through center member. Take care that driving members do not overhang center member outside diameter or damage may result to the elastomer.
3. Apply sufficient pressure to seat the joint in the center of the supporting socket.
4. Attach the supported member snug against the center member.

Figure 1 – Suggested Funnel Design

